

A
B
C
D
E
F

A
B
C
D
E
F

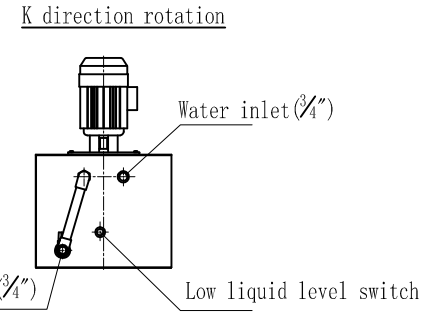
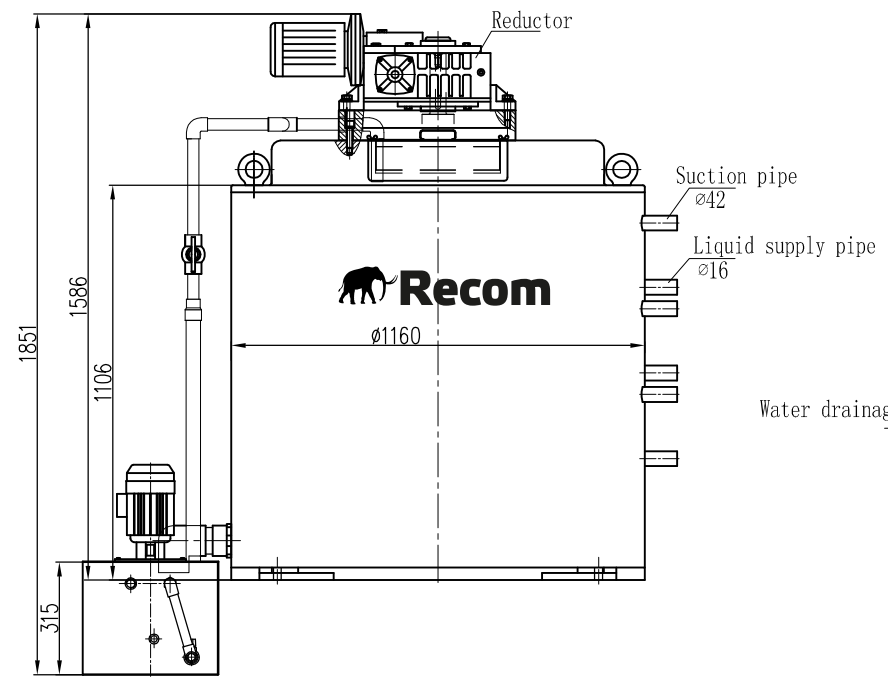

Technical data

| | | |
|--------------------------------------|-------------------------|--------------|
| Standard conditions | water inlet temperature | 16C |
| | Ambient temperature | 25C |
| Evaporating temperature | | -22C |
| Required refrigeration capacity | | 37976Kcal/h |
| Refrigerant | | R404a |
| Ice making capacity | | 8T/24H |
| Power supply | | 3P/380V/50Hz |
| Reductor power (KW) | | 0.55 |
| Water pump (KW) | | 0.25 |
| Weight/set (Kg) | | 830 |
| Outer diameter of liquid supply pipe | | cu16x3 |
| Outer diameter of suction pipe | | cu42x3 |

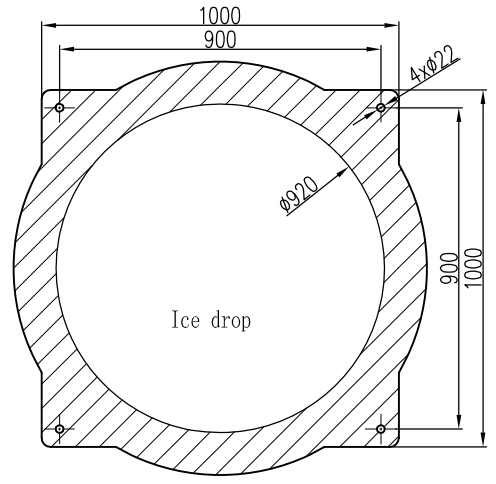
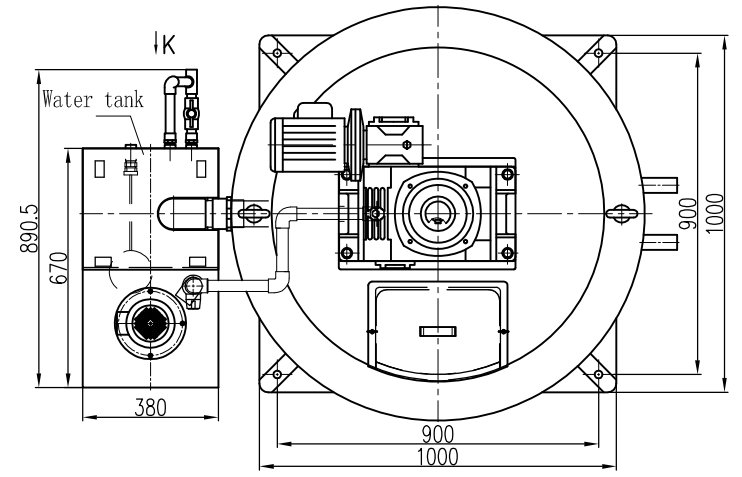

| Itemref | Quantity | Title/Name, designation, material, dimension etc | | | Article No./Reference | |
|-------------|------------|--|-------------------|---------|-----------------------|--|
| Designed by | Checked by | Approved by - date | File name | Date | Scale | |
| | | | 8T FLAKE ICE DRUM | | | |
| RECOM FD80 | | | | Edition | Sheet | |