

Technical date	
Standard operation conditions	water inlet temperature 16C Ambient temperature 25C
Evaporative temperature	-22C
Required refrigeration capacity	11750Kcal/h
Refrigeration	R22
Ice production Capacity	2.5T/24H
Voltage	380V(50Hz) 3P
Reductor power	0.37kw
Water pump	0.03kw
Weight/set	238kg
Outer diameter of liquid receiver	cu16
Outer diameter of return gas pipe	cu35

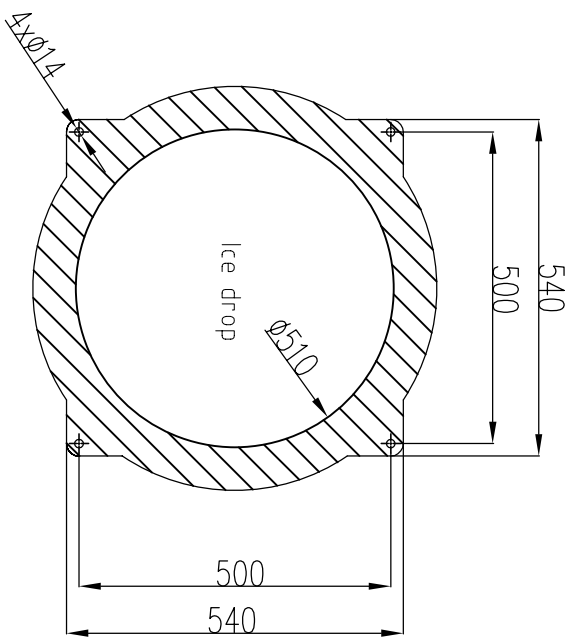

Itemref	Quantity	Title/Name, designation, material, dimension etc	Article No./Reference
Designed by	Checked by	Approved by - date	Filename
RECOM ICE SYSTEMS		2.5T FLAKE ICE MACHINE EVAPORATOR	
F25S		Edition Sheet	