

Technical data

Standard conditions	water inlet temperature	16°C
	Ambient temperature	25°C
Evaporating temperature		-22°C
Required refrigeration capacity		47470Kcal/h
Refrigerant		R404a
Ice making capacity		10T/24H
Power supply		3P/380V/50Hz
Reductor power (KW)		0.75
Water pump (KW)		0.25
Weight/set (Kg)		980
Outer diameter of liquid supply pipe		cu16x4
Outer diameter of suction pipe		cu42x4

A
B
C
D
E
F

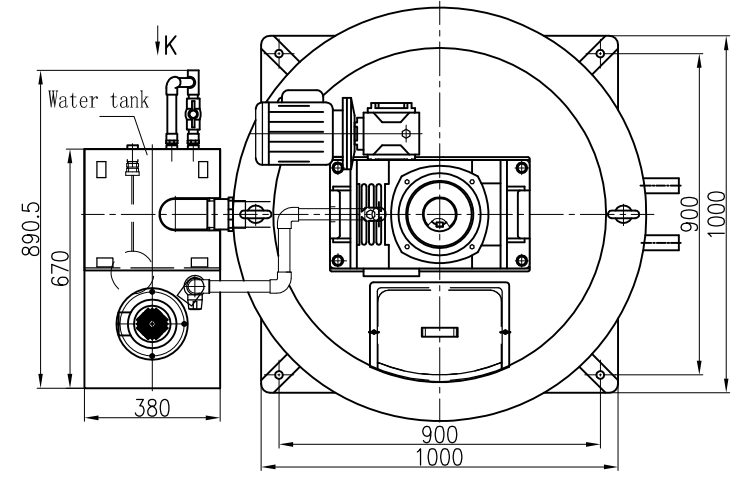
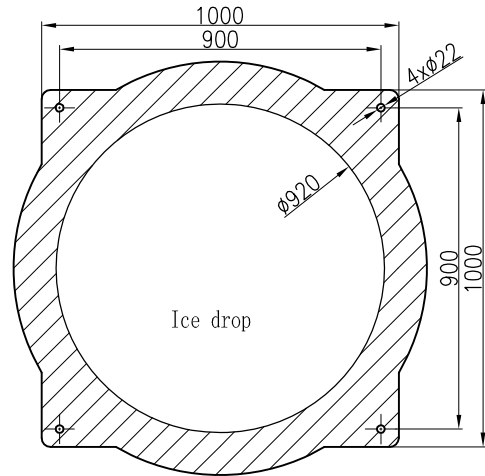
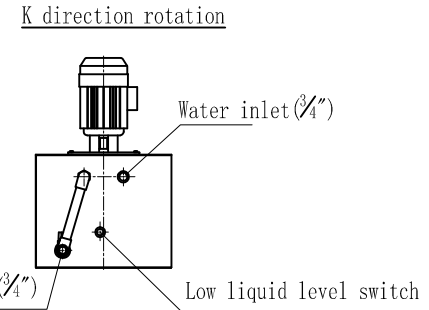
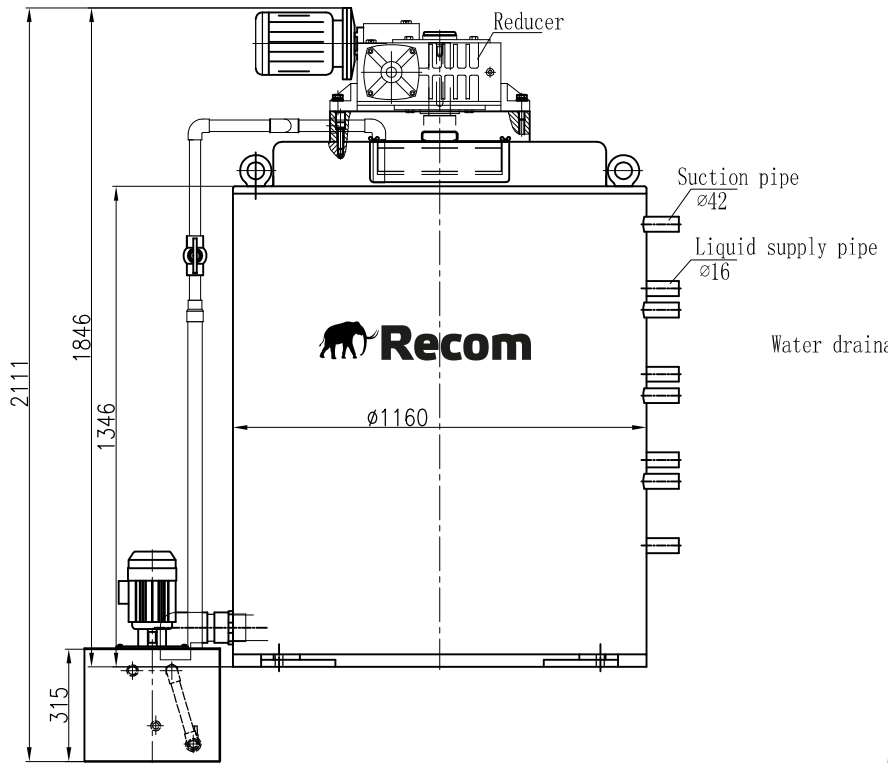

Itemref	Quantity	Title/Name, designation, material, dimension etc			Article No./Reference	
Designed by	Checked by	Approved by - date	File name	Date	Scale	
				10T FLAKE ICE DRUM		
				RECOM FD100	Edition	Sheet

A
B
C
D
E
F