

A direction

Remarks:

- 1, The unit should be indoor
- 2, The equipment should be connected with water pipe, power supply, refrigeration pipeline, according to our instructions;
- 3, This drawing is only for your reference, detailed information is subject to design;
- 4, The delivery range is subject to contract;

Technical parameter:

water inlet temp	25°C
ambient temp	4.0°C
wet bulb temp	25°C
refrigeration capacity	16.96kW
production capacity	3T/24Hr
power supply	4.00V/50Hz/3P
refrigerant	R4.04A
installation power	19kW
power consumption	17.5kW
water consumption	0.125T/Hr
exterior dimension	2000×1600×14.90
running time	about 2.5T

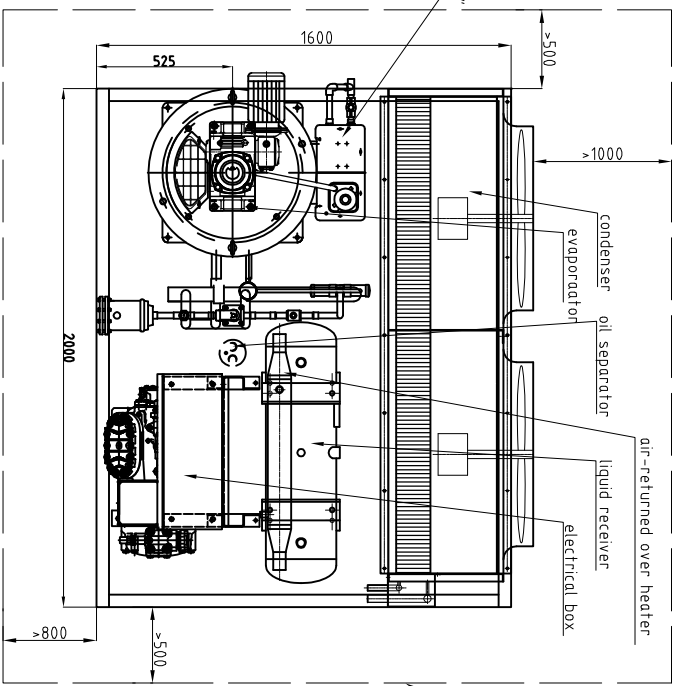

operation and service space

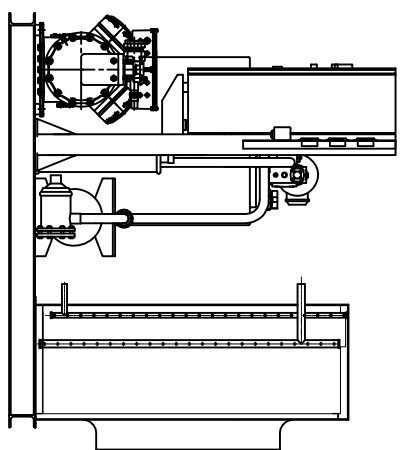

A direction

Item ref	Quantity	Title/Name, designation, material, dimension etc	Article No./Reference
Designed by KANG/WEI	Checked by	Approved by - date	Date 11.03.29
3T flake ice maker layout		File name	Scale
F30AT-5		Revision	Sheet

