

Technical date

Standard operation conditions	water inlet temperature	16°C
	Ambient temperature	25°C
Evaporative temperature		-22°C
Required refrigeration capacity		47000Kcal/h
Refrigeration		R404A
Capacity		10T/24H
Voltage		380V(50Hz) 3P
Reductor power (KW)		0.75
Water pump (KW)		0.25
Weight/set (Kg)		970
Outer diameter of liquid receiver		cu16x4
Outer diameter of return gas pipe		cu42x4

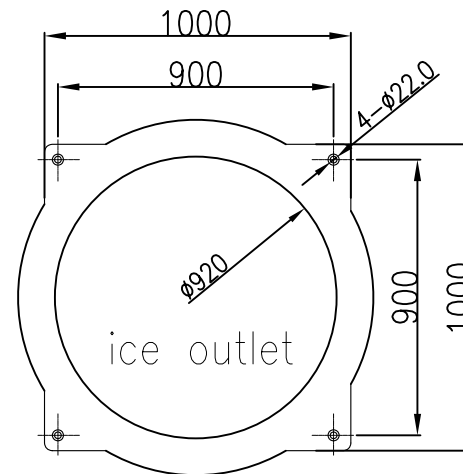
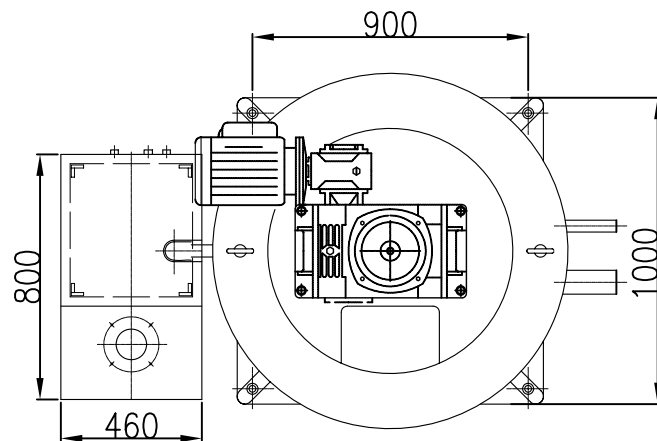
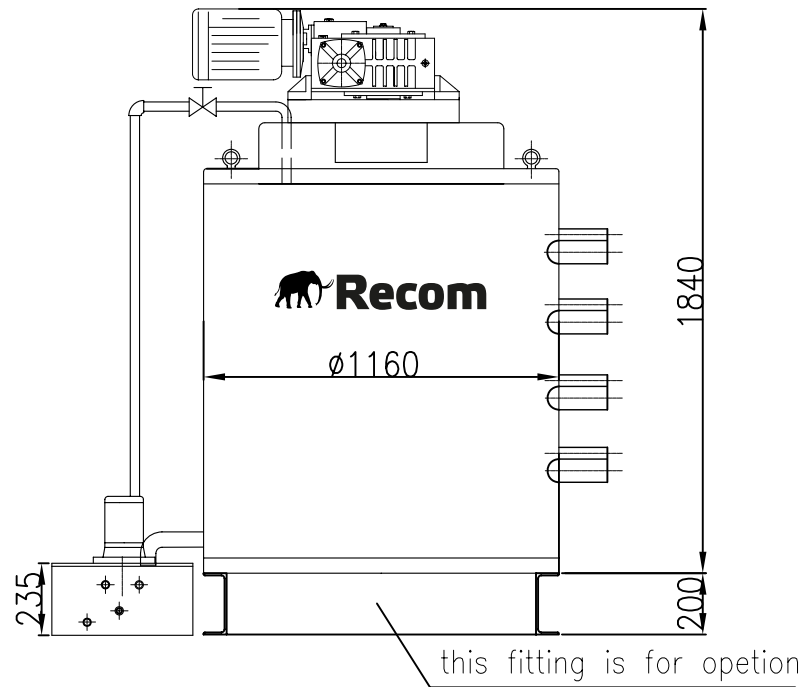

Itemref	Quantity	Title/Name, designation, material, dimension etc			Article No./Reference	
Designed by	Checked by	Approved by - date	File name	Date	Scale	
			10T FLAKE ICE DRUM			
			RECOM FD100		Edition	Sheet